

Make a Proposed Sketch of Office

4. Lay out the graph paper landscape. If you have the ability to tape the graph paper down on your surface using (recommended and preferred) painters' tape.
5. We are going to use the scale $\frac{1}{4}'' = 1'-0''$. I'll show the conversion between a regular ruler and an Architects' Scale, during the live stream.
6. During the presentation you will be drawing a 20'x32' office building with a waiting area (20'x16'), an inner office (12'x16'), and two separate offices (8'x8').
7. Draw a box in the lower right hand corner for the Title Block (about 6 grid squares high by 16 grid squares long).
8. Move up four grid squares from the Title Block and make a mark. This mark is the first corner of the building. With our measurement of 20'x32', the drafter will draw a line (from right to left) that is 8" long representing 32' in length.
9. Next draw a line from the next corner upwards 5" long representing 20' in length.
10. Going from left to right draw another 8" line and then finish the exterior of the building.
11. Next the drafter will mark the interior walls of the building. First measure out 16' (in scale 4") for the office divider from one of the vertical lines. From this mark draw a light line vertically splitting the office in half.
12. Make a mark at 8' (in scale 2") from the bottom horizontal line. Create a horizontal line from the left vertical line to the middle vertical line.
13. Make another mark measuring 8' (in scale 2") from the left vertical line. Create a vertical line from the bottom horizontal line to the middle horizontal line.
14. Next the drafter will place the exterior doors, typical exterior doors are 36". First measure 10' (in scale 2-1/2") and place a mark on the right vertical line.
15. Place the ruler at 0" (zero) on the mark and slide the ruler to left until it reads 1.5' (in scale 3/8") is on the center mark. Place a very light mark there. Repeat this step for the right side of the center mark.
16. Once the drafter has 3 very light marks place the ruler at 0" on the left mark. Move the ruler up till 3' (in scale 3/4") is on the mark. Draw a line from the vertical line to represent the first exterior door.

17. Measure 8' (in scale 2") and place a mark on the bottom horizontal line.
18. Place the ruler at 0" (zero) on the mark and slide the ruler to left until it reads 1.5' (in scale 3/8") is on the center mark. Place a very light mark there. Repeat this step for the right side of the center mark.
19. Once the drafter has 3 very light marks place the ruler at 0" on the left mark. Move the ruler up till 3' (in scale 3/4") is on the mark. Draw a line from the vertical line to represent the second exterior door.

Note: The difference between an interior door and an exterior door is that exterior doors have a threshold. Interior doors do not and therefore the line between the marks are removed (erased). A threshold shows a difference in ground material.

20. Place the interior doors. The first interior door will be placed 2' (in scale 1/2") from the top horizontal line and place a light mark.
21. Place the ruler at 0" (zero) on the mark and slide the ruler to left until it reads 1.5' (in scale 3/8") is on the center mark. Place a very light mark there. Repeat this step for the right side of the center mark.
22. Once the drafter has 3 very light marks place the ruler at 0" on the left mark. Move the ruler up till 3' (in scale 3/4") is on the mark. Carefully Erase the two outer marks and the line leaving the center mark untouched.
23. Repeat steps 21 and 22 for the next two interior doors along the middle horizontal line. One at 6' (in scale 1-1/2") from the left vertical line and one 4' (in scale 1") from the center of the last door.
24. Dimensioning Rules:

- a. Dimensioning starts from the exterior measurements working inward. All exterior dimension vertical lines are 2' (in scale 1/2") from the exterior wall and all horizontal exterior dimension lines are 1' (in scale 1/4") from the exterior wall.
- b. All interior horizontal dimensions are centered in the room unless text is being placed. All vertical dimensions are placed 2' (in scale 1/2") from the closest exterior wall.
- c. All door dimensions are placed 2' (in scale 1/2") from the closest interior wall ending with a vertical line pointing to the center of the door.

- d. All architectural ticks run 45 degrees diagonally from left (at the highest point) to right 1' (in scale 1/4").
- e. All dimension text will be centered on their line in Upper Case Gothic Lettering Format and will have inch annotation following the foot measurement (20'-0").
- f. Vertical text will look the same from top to bottom as turned 90 degrees to the left.
- g. Horizontal text will be readable with the Title Block text.

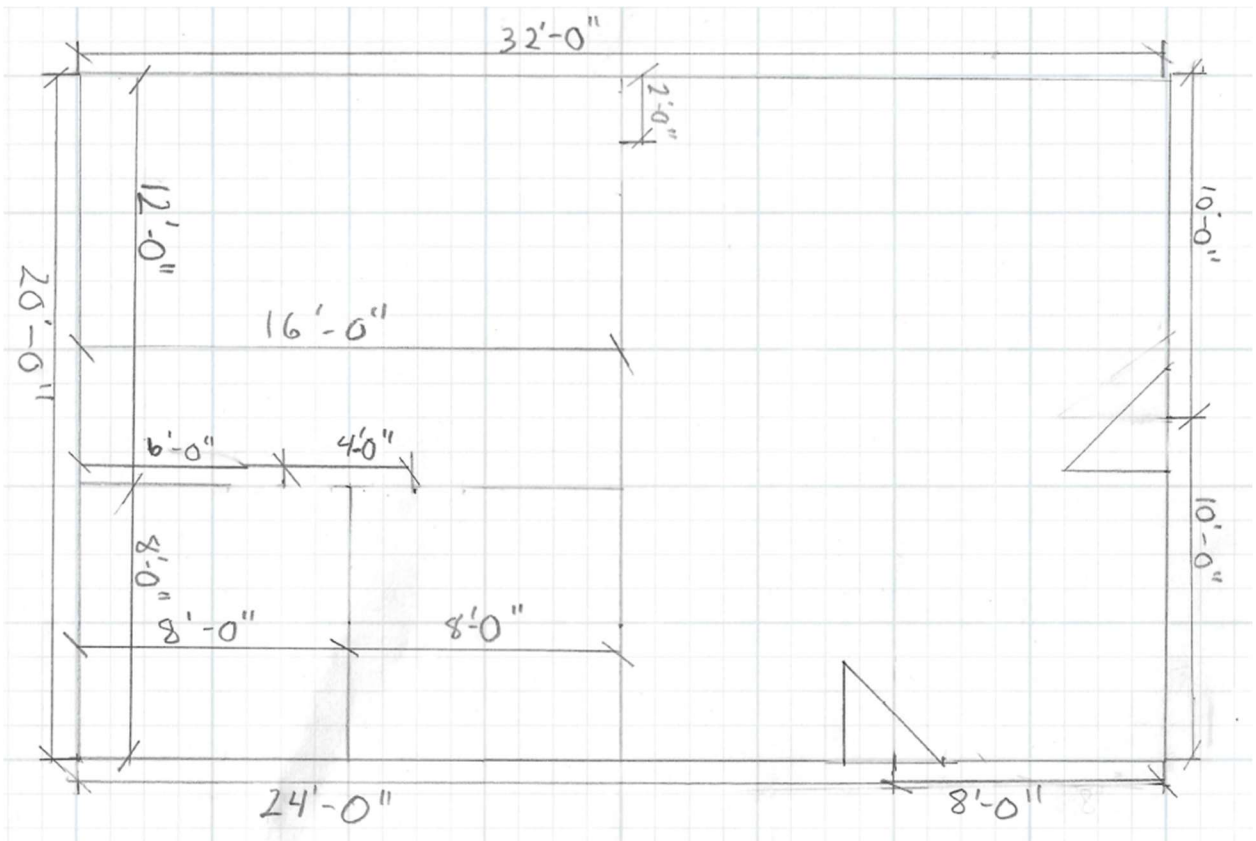

25. Title Block Annotation:

- a. Draw a horizontal line 2 grid squares down from the top line.
- b. Split the box into two sections vertically.
- c. On the right side draw a small horizontal line 1.5 grid squares down.

- d. In the top left box write, "PROJECT:" in the first set of grid squares and below that write "20'x32' OFFICE".
- e. In the top right box write, "DRAWN BY:" in the first set of grid squares and below that write your first and last name.
- f. In the second right box write, "SCALE: 1/4" = 1'-0".
- g. In the bottom right box write, "DATE: 16AUG24", or the day you finish the sketch.

PROJECT: 20'X32' OFFICE	DRAWN BY: JOE SNUFFY
	SCALE: $\frac{1}{4}" = 1'-0"$
	DATE: 16AUG24

Support Bracket (SBRACKET) Specifications (Requirement 3b):

1. New Drawing

1. Select File from the home row tabs and in the drop-down menu select New From Template.

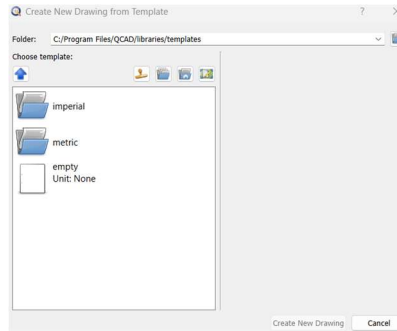

2. First select the Stamp icon (Default Template Directory) and select the Imperial Folder.

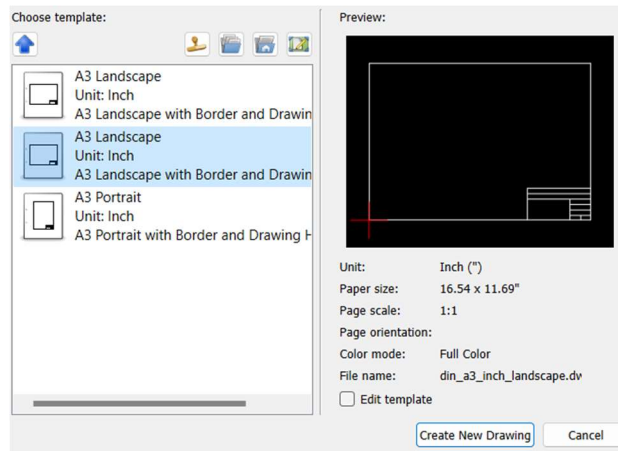

3. Select the middle template (A3 Landscape) and then select Create New Drawing.

2. Layers:

Layer Name	Color	Line Weight	Line Type	Plottable	Snappable
0	White	Default	Continuous	No	Yes
CENTER	Red	0.60 mm	Center	Yes	Yes
DIM	Green	0.30 mm	Continuous	Yes	Yes
HIDDEN	Yellow	0.60 mm	Hidden	Yes	Yes
OBJECT	White	0.60mm	Continuous	Yes	Yes
TEXT	Cyan	0.30 mm	Continuous	Yes	Yes
CLINE	Any	Default	Continuous	No	Yes

INSTRUCTIONS:

1. Setup Dim Styles

- a. Select Edit in the drop-down menu select Drawing Preference

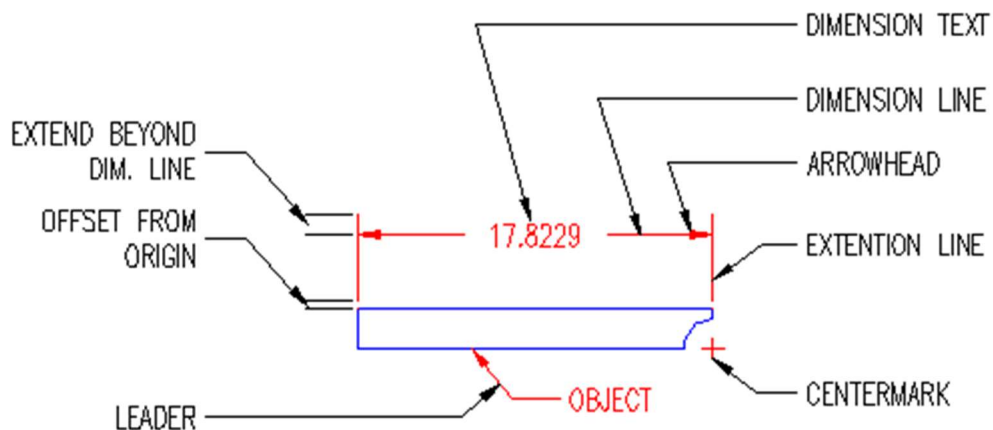

- b. Select Dimension Settings
- c. Edit Dim Styles
 - 1) Dimension Style check Horizontal Text Labels
 - 2) Dimension Style check Text above dimension line.
 - 3) Size
 - i. Uncheck Keep Proportions
 - ii. Text Height: 0.0945
 - iii. Extension Line Extension (Extend Beyond Dim line): 0.0472

- iv. Extension Line Offset (Offset from Origin): 0.0472
 - v. Dimension Line Gap: 0.023625
 - vi. Arrow Size: 0.1417
 - vii. Dimension Line increment (Baseline Dimension): 0.375
 - viii. Size Scale Factor: 1
 - ix. Arrow Style (for mechanical drawings only): Arrow
 - x. Label Font: Arial
 - xi. Label Color: By Layer
 - xii. Linear Dimensions: Format: Decimal / Precision: 0.00
 - xiii. Angular Dimensions: Format: Decimal Degrees / Precision: 0
 - xiv. Select Apply
- 4) Grid: uncheck all viewports
 - 5) Page: Paper Size: ANSI-D

2. Draw Front View:

- a. Turn Off Grid
- b. Line:
 - 1) Type **Line**, then **Enter**.
 - 2) Type **0, 0** then press **Enter**.

Notice that there is now a line connected to the curser. This is known as a rubber band and shows a preview of the line.

Note: Snap Options

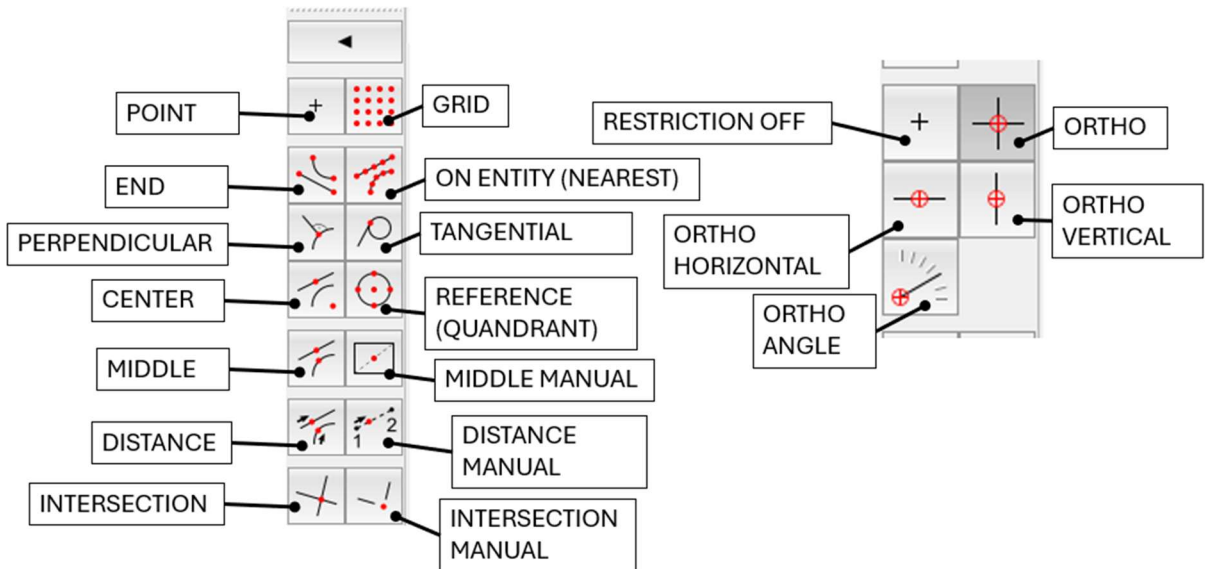

- 3) Move the mouse to the Right and type 4.38, then Enter.
- 4) Move the mouse Up and type 2.38, then Enter.

5) Move the mouse to the Left and type 4.38, then Enter.

6) Type C, then **Enter** to close the box.

3. Offset Top and Right View:

a. Offset:

1) Select Modify in the drop-down menu select Offset (with distance)

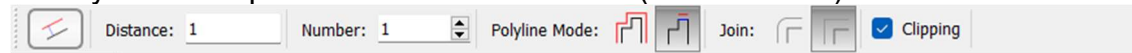

2) In the Tool Ribbon enter the following:

- i. Distance: **2**,
- ii. Number: 1,
- iii. Polyline Mode: Offset Polyline
- iv. Join: Miter Join
- v. Clipping: Checked

3) Hover over the *Top Line* of the *Front View*.

4) Move the mouse **Up** to have a phantom line appear and left click.

There should be a horizontal line 2.0 units above the front view.

4) Hover the *Right Line* of the *Front View*.

5) Move the Mouse **Right** and left click.

There should be a vertical line 2.0 units to the right of the front view.

4. Finish drawing the *Top* rectangle.

a. Line:

1) Type **Line**, then **Enter**.

2) Select the *Right* side of the line.

3) Move the mouse **Up** and type **2.12**, then **Enter**.

4) Move the mouse Left and type 4.38 Enter.

5) Move the mouse Down and type 2.12, then Enter.

6) Hit **Escape** on the keyboard to close the command.

5. Finish drawing the *Right* rectangle.

a. **Line:**

- 1) Type **Line**, then **Enter**.
- 2) Select the *Bottom* of the line.
- 3) Move the mouse to the *Right* and type **2.12**, then **Enter**.
- 4) Move the mouse to the *Up* and type **2.38**, then **Enter**.
- 5) Move the mouse *Left* and type **2.12**, then **Enter**, or select the end point at the top of the initial line.
- 6) Hit **Escape** on the keyboard to close the command.

6. Draw Miter Line

The Miter Line is a line that divides the top and right side views at a 45° angle. It is used to project lines to and from these views.

a. **Active Layer:**

- 1) On the right side of the screen select **CLINE**.

There should be a pencil next to the layer CLINE identifying that CLINE is the current active layer.

b. **Line:**

- 1) Type **Line**, then **Enter**.
- 2) Left click to the *Top Right Corner* of the *Front View*.
- 3) Type **@6<45**, then **Enter**.
- 4) Hit **Escape** on the keyboard to close the command.

Note: Orthographic Projections should start with three views and a miter line, as shown in Figure below.

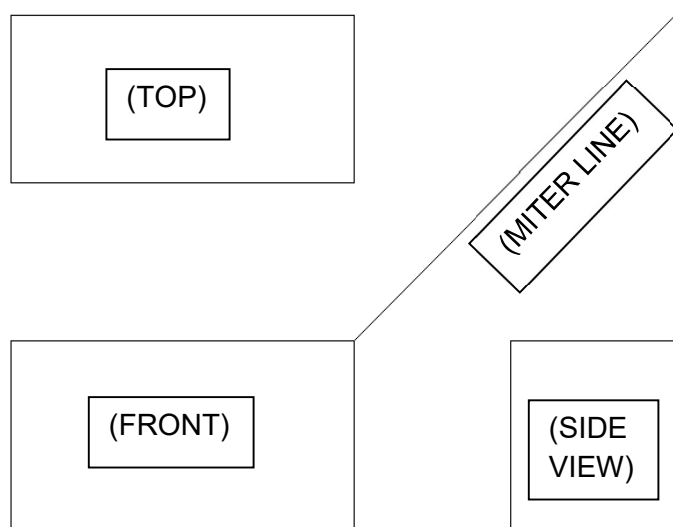

7. Draw Details of the Front View

a. Active Layer:

- 1) On the right side of the screen select **OBJECT**.

b. Offset Horizontal Line:

- 1) Type **OF**, then **Enter**.
- 2) Distance **0.38**, then **Enter**.
- 3) Hover over the *Bottom* line of the *Front View*.
- 4) Move the mouse up, then left click.

A new line should appear 0.38 above the bottom line.

- 5) Hit **Escape** on the keyboard to close the command.

c. Offset Horizontal Line:

- 1) Hit **Enter** to re-open the **Offset** command.
- 2) Distance **0.85**, then **Enter**.
- 3) Hover over the *Bottom* line, move the mouse **Up**, then left click again.

d. **Offset Vertical Line:**

- 1) Hit **Enter** to re-open the Offset Command.
- 2) Distance **2.12**, then **Enter**.
- 3) Hover over the *Left* vertical line, move the mouse **Right**, then left click again.
- 4) Hit **Escape** on the keyboard to close the command.
- 5) Hit **Enter** on the keyboard to re-open the offset command.
- 6) Distance **0.38**, then **Enter**.
- 7) Hover over the *Previous* line that was offset.
- 8) Move the mouse **Right** and left click.

e. **Draw Diagonal Line:**

- 1) Draw a line from the *Top Right Vertical Line*, to the *Top Right Horizontal Line*.

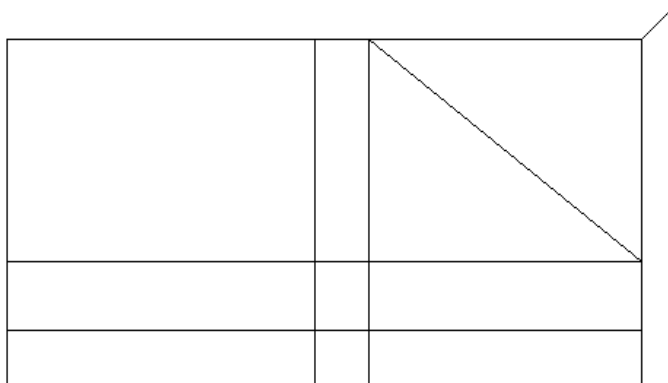

f. **Trim:**

Use the Dynamic Trim Mode to delete excess lines.

- 1) Select Modify in the drop-down menu select Trim.
- 2) Choose the Limiting Entity, this is object/line/etc. that the drafter wants to have a polyline stop at or have the End Point changed to start/stop at the

limiting entity. Select the vertical line where the diagonal line is touching the top horizontal line.

- 3) Next select the top horizontal line behind the Limiting Entity. You should see the top horizontal line Trim at the Limiting Entity and the excess line deleted.
- 4) Hit **Escape** on the keyboard to close the command.
- 5) Hit **Enter** on the keyboard to re-open the trim command.
- 6) Choose the Limiting Entity, select the horizontal line where the diagonal line is touching the second horizontal line from the top.
- 7) Next select the far right vertical line below the Limiting Entity. You should see the right vertical line Trim at the Limiting Entity and the excess line deleted.
- 8) Hit **Escape** on the keyboard to close the command.
- 9) Continue using the Trim command until your Front View looks like the image below.

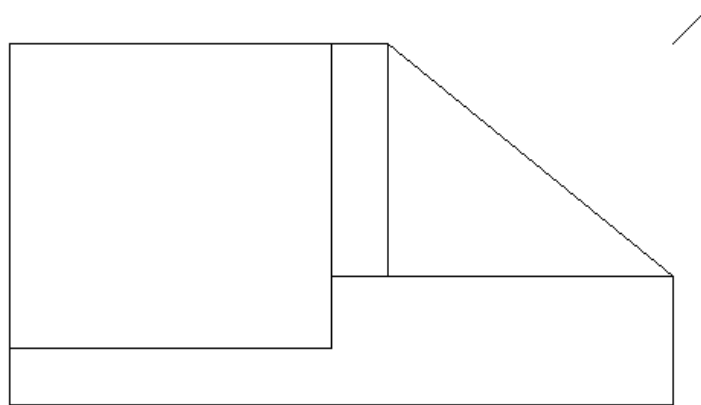

g. Offset Horizontal Lines for Circle Location:

- 1) Change Active Layer to **CLINE**.
- 2) Type **OF**, then Distance **1.01**.
- 3) Hover over the *Bottom Line*, drag the mouse **Up**, then left click again.
- 4) Hit **Escape** on the keyboard to close the command.
- 5) Hit **Enter** on the keyboard to re-open the offset command.

- 6) Distance **0.75**, hover over the previous offset line.
- 7) Move the mouse **Up**, then left click again.
- 8) Hit **Escape** on the keyboard to close the command.

h. Offset Vertical Line for Circle Location:

- 1) Type **Offset**, then type **0.62**.
- 2) Hover over the *Left Line*, drag the mouse **Right**, then left click again.
- 3) Hit **Escape** on the keyboard to close the command.

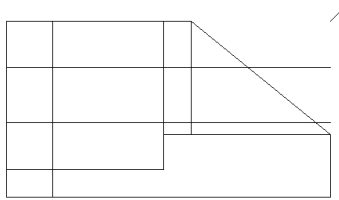

i. Draw Circles:

Place two circles at the intersections of the offset lines with a radius of 0.22.

**Note: Ensure Intersection is enabled under OSNAPs*

- 1) Change Active Layer to **OBJECT**.
- 2) Type **CR** (Circle at **C**enter **R**adius), then **Enter**.
- 3) In Radius type **0.22**, then **Enter**.
- 4) Left click on the intersection of the Bottom Horizontal Line, and the Vertical Line.
- 5) Repeat step 4, but place a circle at the intersection of the Top Horizontal Line and the Vertical Line.
- 6) Hit **Escape** on the keyboard to close the command.

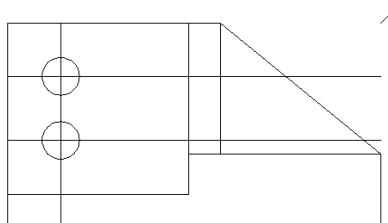

j. **Connect the Circles:**

- 1) Draw lines between the *Left Quadrants (References)* and the *Right Quadrants* of the two circles.

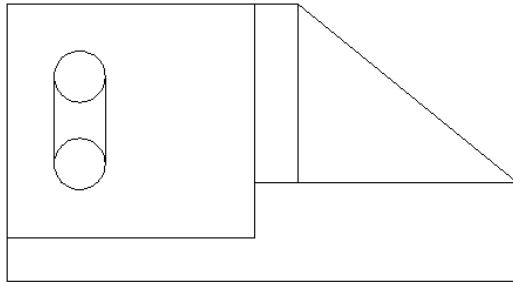

k. **Delete and Trim Lines:**

- 1) Delete the horizontal and vertical lines used to find the location of the circles.
- 2) Type **D2** (Break out Segment), then Enter.
- 3) Carefully select the inside portions of the circles to match the image below (should be four left clicks).

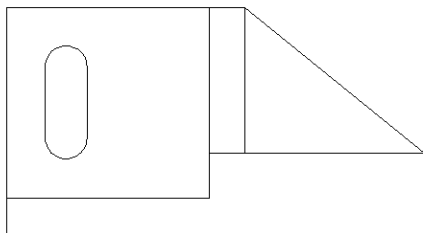

8. **Draw Details for the Top View:**

- a. **Offset:** Offset the *Top Line Down* by **0.38**.

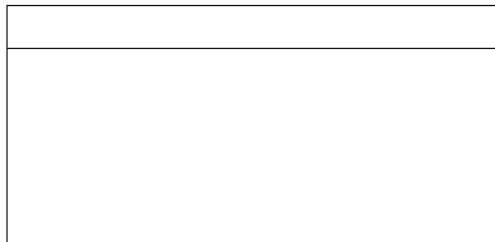

Use the Front View to project lines into the Top View.

- b. **Projection Lines:** Draw two lines from the Endpoints of the vertical lines from the *Front View*, perpendicular to the *Horizontal Lines* in the *Top View*

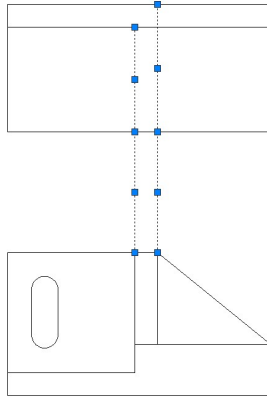

- c. **Trim:** Use Dynamic Trim Mode (**RM**) to delete line segments *Between the Front and Top View*.

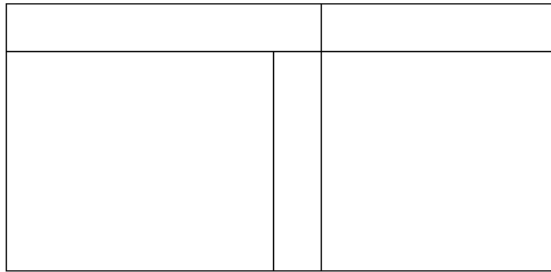

- d. Change the Active Layer to **CLINE**.
- e. Create the Vertical Construction Lines; Location of the Right circle is 0.50 from the Right Side and Left Circle is 0.88 from the Right Circle.
- f. Create the Horizontal Construction Line; Location of the circles is 1.26 Down from the Top Line.

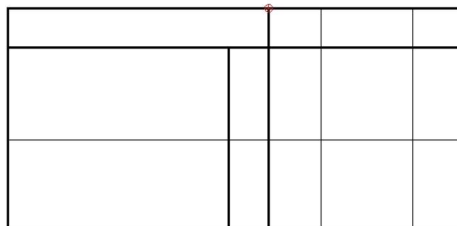

- g. Change the Active Layer to **OBJECT**.
- h. **Draw Circles:** Diameter (\emptyset) of the circles is 0.50 by typing **CA** (Center Diameter) in the command line.

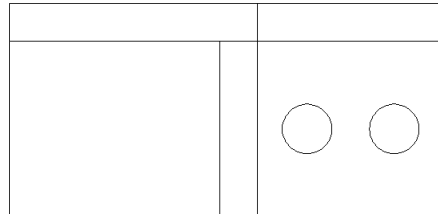

i. **Draw Fillet:**

- 1) Type **RN** (Round), then **Enter**.
A Fillet is curve connecting two surfaces.
- 2) Drafting software need to know the radius of the fillet before the sides are selected, for this software the radius is inputted in the upper ribbon.
- 3) Type **1.5**, then **Enter**.
- 4) Left click on the bottom line then the left line, by selecting just outside of the top view.

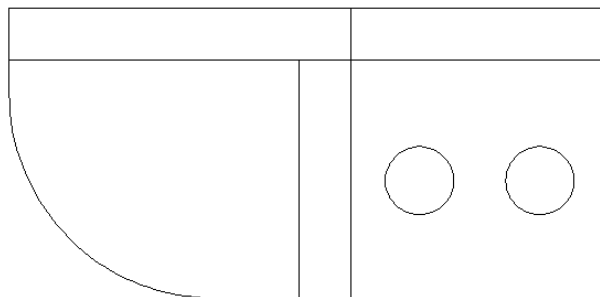

9. Draw Details of the Side View:

- a. Change the Active Layer to **CLINE**.
- b. Projection Line 1: Draw a horizontal line from the Top View to the Miter Line creating an Intersection Point.
- c. Projection Line 2: Draw a vertical line from Miter Line down to the Side View.
- d. Projection Line 3: Draw a horizontal line from the Front View to the Side View.

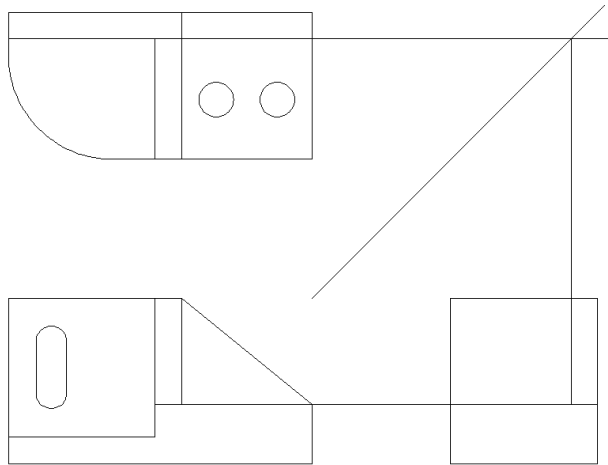

- e. Change the Active Layer to **OBJECT**.
- f. Draw two lines to finish the image above using the Projection Lines previously created.
- g. **Angle Line:** Draw a line to make the angle in the upper left corner.
- h. **Trim and Delete:** Trim line segments between views.

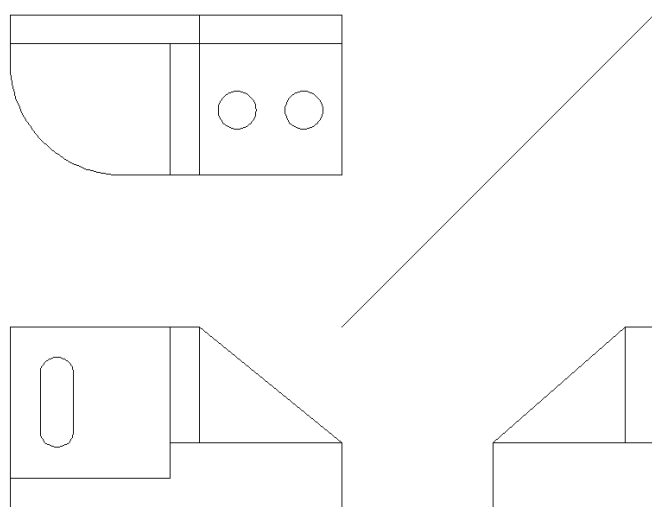

10. Draw Hidden Lines:

Hidden lines show objects which are not visible in the view. Every surface and hole needs to be shown in all three views

- a. Change the Active Layer to **HIDDEN**.
- b. **Projection Lines:** Use the *Hidden Layer* and draw projecting lines from one view to another.

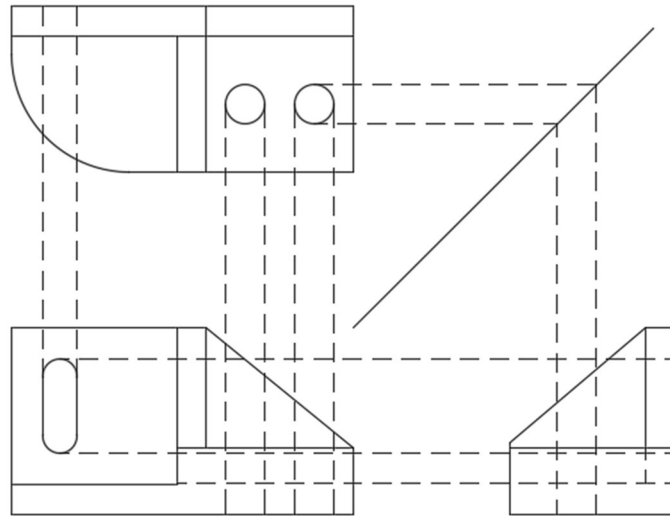

- c. **Trim:** Use the *Trim Command* to delete any excess lines within all three views.

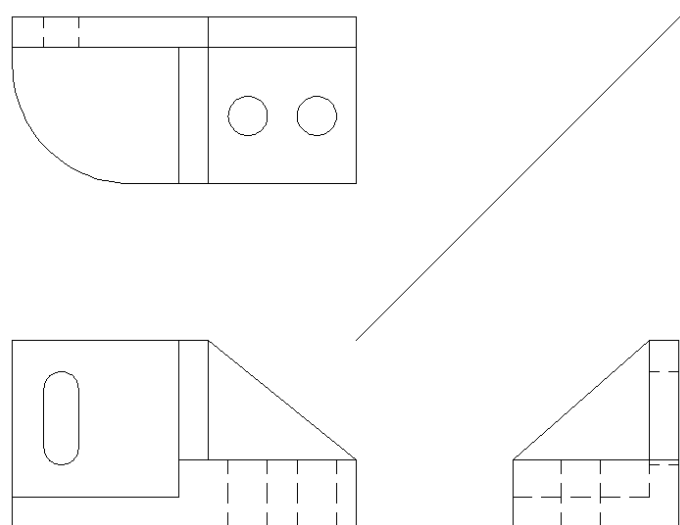

11. Draw Center Marks:

Center marks identify the center and edges of arcs and circles.

- Change the Active Layer to **CENTER**.
- For this drafting software Center Line Marks are a Misc accessory under Draw called Center Cross (**CS**).

- c. Left click on *Right* circle in the *Top View*. A center mark will appear.
- d. Select the Two Arcs in the Front View, and the Fillet in the Top View.

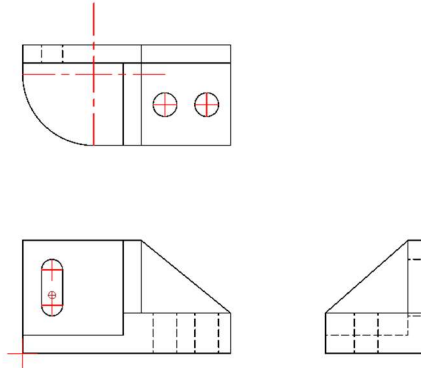

- e. Trim the Top and Right center mark lines within the *Top View*.
- f. Delete the top circle's center vertical line and select the bottom center vertical line.
- g. Stretch the bottom circle's center vertical line to the top circle's top quadrant.

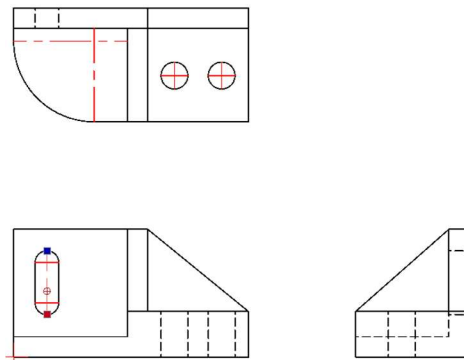

12. Draw Center Lines:

A Center Line will represent the center of a thru-hole

- a. **Projection Lines:** Use the projection process to transfer all center lines to each view.

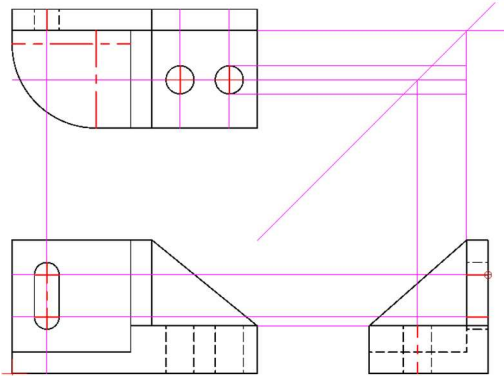

b. **Trim:** Use the *Trim Command* to delete any excess lines within all three views.

c. **Stretch Center Lines:**

Center Lines should have a Long-Short-Long appearance and extend past the object line 1/8".

- 1) Left click on a center line.
- 2) Grab the *Endpoint* grip.
- 3) Move the mouse **Up**, type **0.125**, then **Enter**.
- 4) Repeat the stretch command on all Center Lines on both sides.

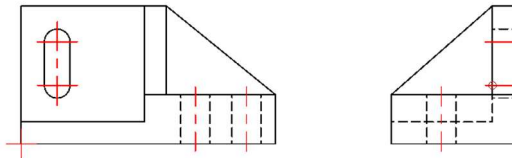
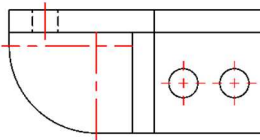

d. **Linetype Scale:**

Linetype Scale needs to be adjusted within properties to create a Long-Short-Long appearance.

- 1) **Properties:** Select the Center Line on the Top View and select the **View** tab and in the drop-down menu select **Property Editor** button, or type **GP**, then **Enter**.

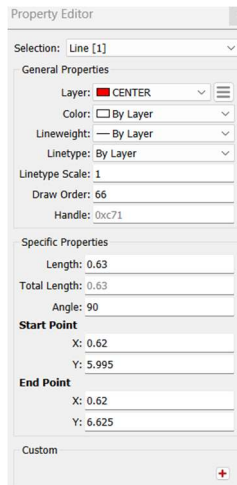

- 2) **Scale:** Change the Linetype Scale to **0.5**. If the Center Line does not appear to be Long-Short-Long, type 0.2500 within the Linetype Scale.

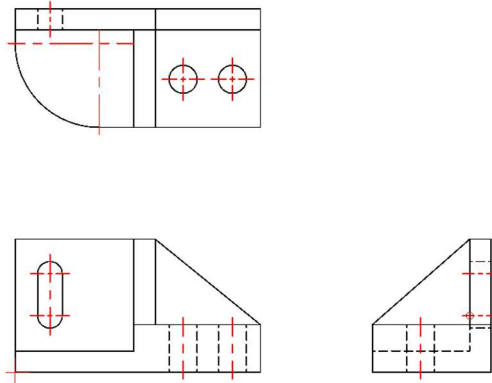

13. Offsets for Dimensions:

- a. **Layer:** Switch the *Layer* to **CLINE**
- b. **Offset:** Offset all sides that will have dimensions by 0.375.

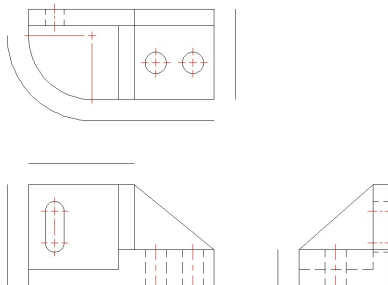

14. Place Drawing Annotations

a. Linear Dimension:

The first dimension to be completed is always a linear dimension.

- 1) Switch the *Layer* to **DIM**.
- 2) In the main tabs select Dimension and in the drop-down menu select Aligned.
- 3) Select the Lower Left corner of the Front View.
- 4) Move the mouse **Up** and select the *Left Endpoint* of the next horizontal line.
- 5) Move the mouse to the *Left* and click on the offset line.
- 6) After the dimension has been placed, highlight the dimension.

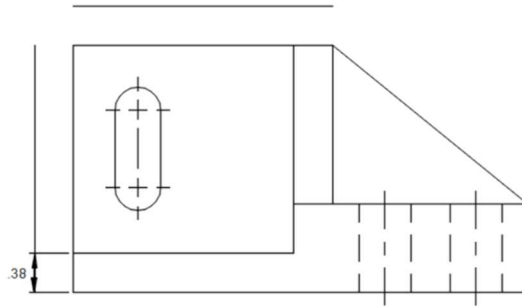

b. Baseline Dimension:

A Baseline Dimension is a dimension that is positioned above another dimension line.

- 1) Select the Baseline Dimension in the Dimension drop-down.
- 2) The dimension will automatically populate within the drawing.
- 3) Click on the Bottom Left Endpoint of the center mark.

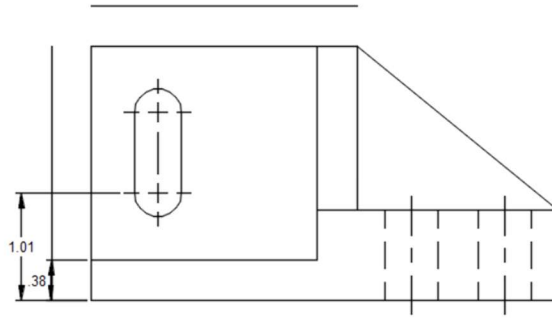
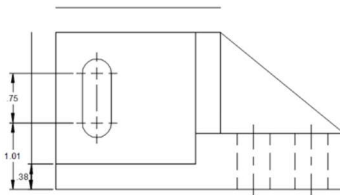

Figure 3.90

c. Continuous Dimension:

A Continuous Dimension is a dimension that continues off another dimension line.

- 1) Select the Continuous Dimension in the Dimension drop-down.
- 2) The dimension will automatically populate within the drawing.
- 3) Click on the Top Left Endpoint of the center mark.



Use the *Linear*, *Continuous* and *Baseline* dimensioning process to complete all three views.

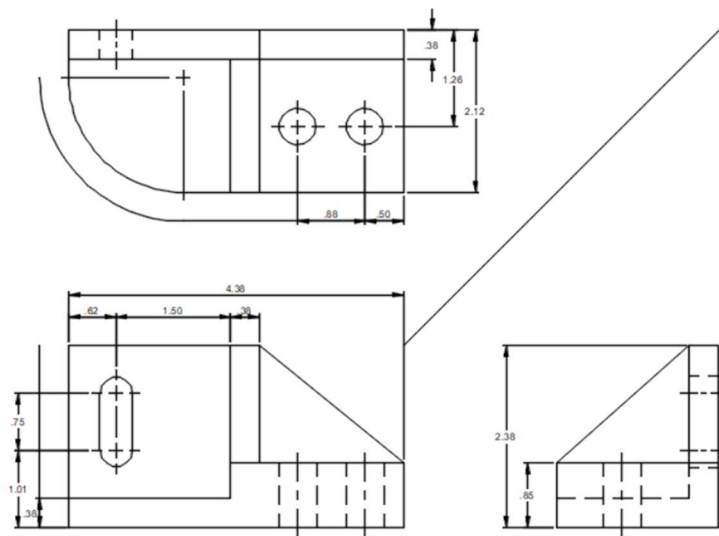

d. Leader Lines:

A Leader Line contains a leader arrow, leader line (with landing) and a note.
Note: Ensure Nearest is enabled within OSNAPS.

- 1) Switch Layer to the **Text**.
- 2) Select Text in the Draw drop-down.

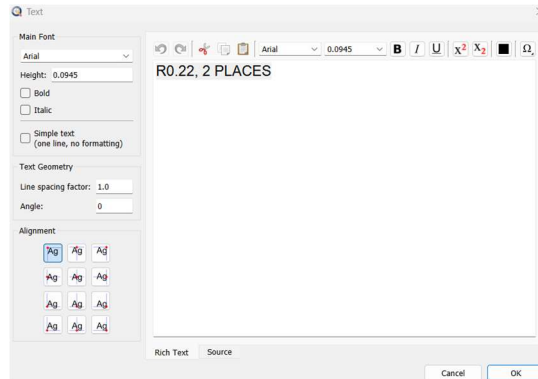

- 3) Change the height to 0.0945 and enter the desired text.
- 4) Select the top end of the left vertical Construction Line used for dimensions.
- 5) Select the newly created text and the select Move in the Modify drop-down.
- 6) Using the Restriction (Ortho) Horizontal and Point Snap move the text to where the last entity of the text is just behind the Construction Line.
- 7) Select Delete Original once the text is moved into place and select OK.

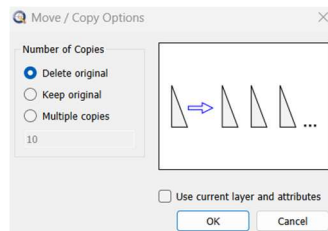
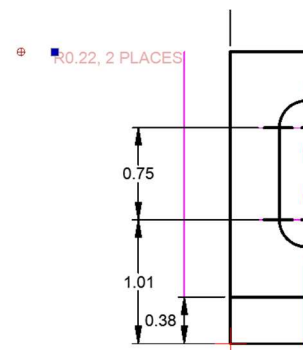
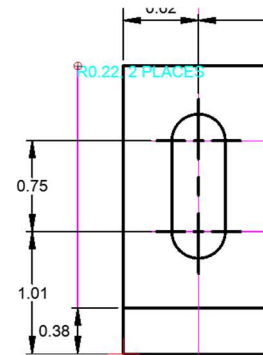

- 8) In the Misc drop-down select Draw and in its right scrolled menu select Text Aligned Leader.
- 9) In the first prompt (command line) for Arrow Position select the End of the top circle's horizontal center mark line.
- 10) In the second prompt for Choose Text select the newly created text. A leader line will be generated.

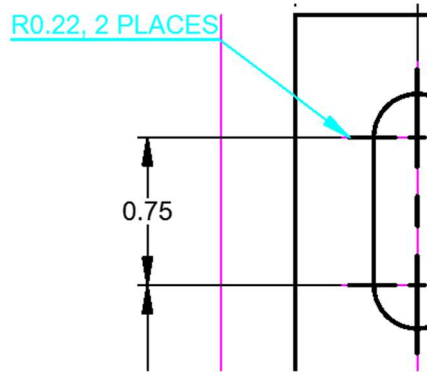

Use the Leader Dimensioning process to complete all three views.

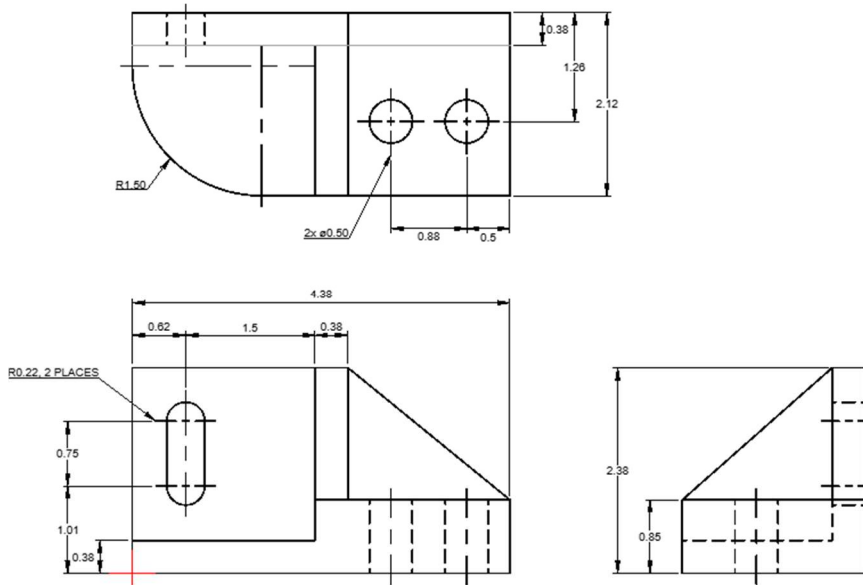

15. Preparing to Plot the Proposed Project

a. Establishing Title Block information

- 1) Enter Title Block section titles by selecting Text under the Draw drop-down
- 2) Project – What is the project called?

- 3) Drawn By – Who drafted the project?
 - 4) Scale – What is scale of the project?
 - 5) Date – The date the drafted project went in for revisions or finished plot.
 - 6) Sheet Size – The size of the sheet of paper the project is intended to be plotted on.
 - 7) DWG NO – Most firms have a drawing numbering system for projects and within the project some specialty items or features will have a specific number.
 - 8) Title – The title of the sheet if any.
- b. Fill in the Title Block with all critical information.

PROJECT: SBRACKET	
DRAWN BY: NICK LAWTON	
	SCALE: 1:1
	DATE: 28 JULY 2024
	SHEET SIZE: ANSI A
	DWG NO: 1 TITLE: